

A. A. Pankov^{1,2,3}, I. A. Serenkova¹, A. V. Tsytrinov¹, V. A. Bednyakov³

¹*Abdus Salam ICTP Affiliated Centre at Sukhoi State Technical University of Gomel, Gomel, Belarus*

²*Institute for Nuclear Problems of the Belarusian State University, Minsk, Belarus*

³*Laboratory of Nuclear Problems, JINR, Russia*

PROSPECTS FOR IDENTIFYING NEW PHYSICS SCENARIOS AT CERN LHC

Abstract. The signatures of the spin-2 graviton excitations predicted by the Randall – Sundrum model with one warped extra dimension, in dilepton and diphoton production at LHC were studied. By using the center – edge asymmetry, we evaluate the ranges of mass and coupling constant where such gravitons can be discriminated against competitor spin-1 and spin-0 objects that could potentially manifest themselves in these processes. Depending on the value of coupling constants, the numerical results allow one to obtain graviton identification mass ranges of the order of 2.4 TeV and 3.2 TeV for LHC nominal energy of 14 TeV and time-integrated luminosity of 100 fb⁻¹.

Keywords: Large Hadron Collider (LHC), physics beyond the standard model, Randall – Sundrum (RS) model with warped extra dimension, dilepton and diphoton production

For citations. Pankov A. A., Serenkova I. A., Tsytrinov A. V., Bednyakov V. A. Prospects for identifying new physics scenarios at CERN LHC. *Vestsi Natsyianal'nai akademii navuk Belarusi. Seryia fizika-matematychnykh navuk = Proceedings of the National Academy of Sciences of Belarus. Physics and Mathematics series*, 2017, no. 4, pp. 33–38.

А. А. Панков^{1,2,3}, И. А. Серенкова¹, А. В. Цитринов¹, В. А. Бедняков³

¹*Филиал Международного центра теоретической физики им. А. Салама,*

Гомельский государственный технический университет им. П. О. Сухого, Гомель, Беларусь

²*Институт ядерных проблем Белорусского государственного университета, Минск, Беларусь*

³*Лаборатория ядерных проблем им. В. П. Джелепова, ОИЯИ, Россия*

ПЕРСПЕКТИВЫ ИДЕНТИФИКАЦИИ НОВЫХ ФИЗИЧЕСКИХ СЦЕНАРИЕВ НА КОЛЛАЙДЕРЕ LHC В ЦЕРНЕ

Аннотация. Исследованы эффекты возбужденных состояний гравитонов со спином 2, предсказываемых моделью Рендалл – Сандрума с одним искаженным дополнительным измерением, в процессах дилептонного и дифотонного рождения на Большом адронном коллайдере LHC. С помощью асимметрии центр-край мы оцениваем интервал масс и констант связи, где такие гравитоны могут отличаться от конкурирующих объектов со спином 1 и 2 в исследуемых процессах. В зависимости от величины констант связи численный анализ позволяет определить область идентификации масс гравитона, верхняя граница которого составляет 2,4 и 3,2 ТэВ для LHC с номинальной энергией 14 ТэВ и интегральной светимостью 100 фб⁻¹.

Ключевые слова: Большой адронный коллайдер (LHC), физика за рамками Стандартной модели, модель Рендалл – Сандрума (RS) с искаженным дополнительным измерением, рождение дилептонов и дифотонов

Для цитирования. Перспективы идентификации новых физических сценариев на коллайдере LHC в ЦЕРНе / А. А. Панков [и др.] // Вес. Нац. акад. навук Беларусі. Сер. фіз.-мат. навук. – 2017. – № 4. – С. 33–38.

Introduction. Extra spatial dimensions were proposed to investigate the mass scale hierarchies affecting the Standard Model (SM), and requiring parameter fine tuning, in particular the so-called gauge hierarchy $M_{EW} \ll M_{Pl} \sim 10^{16}$ TeV. These scenarios predict the existence of heavy new particles, or excitations of the SM particles, that could be revealed as narrow peaks in cross sections measured at the LHC if their masses were below the experimental kinematical reach. In this regard, the discovery reach on an individual scenario can be defined as a maximum value of the corresponding resonance mass, M_R , for which the peak can be observed. However, different new physics scenarios can give, for appropriate values of their parameters, peaks at the same $M = M_R$ and the same number of events under the peak. Accordingly, one defines for any non- standard scenario an identification mass range, where it can be unambiguously discriminated as the one really underlying the peak, by excluding the other models as potential sources of that same peak. The determination of the spin of a discovered heavy resonance is, therefore, crucial for its identification. We will here discuss the identification of the spin-2

graviton excitation predicted by the RS model with one warped extra dimension [1], against the spin-1 and the spin-0 hypotheses for a heavy neutral resonance discovered in dilepton and diphoton inclusive production at the LHC:

$$pp \rightarrow l^+l^- + X, \quad pp \rightarrow \gamma\gamma + X, \quad (1)$$

where $l = e, \mu$. In case of the spin-1 particle we will consider the Z' bosons predicted by extended electroweak gauge symmetries, and the spin-0 particles will be modeled by the sneutrinos ($\tilde{\nu}$) envisaged by R -parity violating SUSY extensions of the SM. ‘Confusion’ domains of their respective parameter spaces allowed by current experimental constraints exist, in which s -channel exchanges of the above mentioned particles can in the process (1) produce narrow peaks in the dilepton invariant mass with the same values of mass and event rates. Therefore, for the spin-2 hypothesis discrimination against the two alternative ones, more detailed information must be supplied, i.e., that embodied in the characteristic angular distributions of the different scenarios.

1. Spin determination of heavy resonances. The basic observable for a heavy resonance discovery at an invariant dilepton (or diphoton) mass $M = M_R$ (with in our case $R = G, Z', \tilde{\nu}$ denoting graviton, extra gauge boson and sneutrino, respectively) is the production cross section governing the rate of events

$$\sigma(pp \rightarrow R) \cdot BR(R \rightarrow l^+l^-) = \int_{-z_{cut}}^{z_{cut}} dz \int_{M_R - \Delta M/2}^{M_R + \Delta M/2} dM \int_{-Y}^Y dy \frac{d\sigma}{dM dy dz}, \quad (2)$$

and the differential angular distribution

$$\frac{d\sigma}{dz} = \int_{M_R - \Delta M/2}^{M_R + \Delta M/2} dM \int_{-Y}^Y dy \frac{d\sigma}{dM dy dz}. \quad (3)$$

In Eqs. (2) and (3), $z = \cos\theta_{cm}$ and y define the lepton-quark (or photon-quark) angle in the dilepton (or diphoton) center-of-mass and the dilepton rapidity, respectively, and cuts on phase space due to detector acceptance are indicated. Here, ΔM is an invariant mass bin around M_R , reflecting the detector energy resolution, see for instance. To evaluate the number N_S of resonant signal events, these equations must be multiplied by the time-integrated luminosity, for which we will take 100 fb^{-1} , and by the foreseen reconstruction efficiencies (90 % for both electrons and muons). Finally, with N_B the number of ‘background’ events in the ΔM bin, determined by the SM predictions, the criterion $N_S = 5\sqrt{N_B}$ or 10 events, whichever is larger, will be adopted as the minimum signal for the peak discovery.

Center-edge angular asymmetry can be written as follows

$$A_{CE} = \frac{\sigma_{CE}}{\sigma}, \quad (4)$$

where

$$\sigma_{CE}(z^*) = \left[\int_{-z^*}^{z^*} - \left(\int_{-z_{cut}}^{-z^*} + \int_{z^*}^{z_{cut}} \right) \right] \frac{d\sigma}{dz} dz, \quad \sigma = \int_{-z_{cut}}^{z_{cut}} \frac{d\sigma}{dz} dz.$$

In Eq. (4), $0 < z^* < z_{cut}$ defines the separation between the ‘‘center’’ and the ‘‘edge’’ angular regions, and is a priori arbitrary. However, its actual value can be ‘‘optimized’’ in the numerical analysis. A further potential advantage of A_{CE} is that, as consisting of ratios of integrated cross sections, it could be less sensitive to systematic uncertainties, such as those stemming from particular choices of parton distributions, K -factor values, etc.

1. New physics models and observables

1.1. RS model with one compactified warped extra dimension. This simplest version consists of one warped extra dimension, y , two three-dimensional branes placed at a compactification relative distance πR_C in y , and the specific 5-D metric

$$ds^2 = \exp(-2k|y|)\eta_{\mu\nu}dx^\mu dx^\nu - dy^2, \quad (5)$$

where $\eta_{\mu\nu}$ is the usual Minkowski tensor and $k > 0$ is dimensionful constant. The SM fields are assumed to be localized to the so-called TeV brane, while gravity can propagate in the full 5-D space, in particular on the other brane, the Planck brane, in which the effective 4-D mass scale is $\bar{M}_{Pl} = 1/\sqrt{8\pi G_N} = 2.44 \cdot 10^{15}$ TeV. With M_* the 5-D mass scale, analogously related to the cubic root of the 5-D gravitational constant, Einstein's equations imply the relation $\bar{M}_{Pl}^2 = (M_*^3/k)(1 - \exp(-2k\pi R_C))$, and the basic ‘‘naturalness’’ assumption imposed on the model, to avoid further fine tunings, is $\bar{M}_{Pl} \sim M_* \sim k$. The geometry of Eq. (5) implies that the mass spectrum on the Planck brane, of the order of 10^{15} TeV, can for $kR_C \sim 11$ be exponentially ‘warped’ down to the TeV brane where SM particles live, by many orders of magnitude, namely, to the scale $\Lambda_\pi = M_{Pl} \exp(-k\pi R_C) \sim 1$ TeV. The appealing consequence is then that gravitational effects can occur in the reach of supercolliders, such as the LHC. Indeed, junction conditions at the brane y -positions imply, for the above value of kR_C , the existence of a tower of spin-2 graviton excitations, $h_{\mu\nu}^{(n)}$, with a specifically spaced mass spectrum $M_n = x_n k \exp(-k\pi R_C)$ of order TeV (x_n are here the roots of $J_1(x_n) = 0$). Their couplings to the SM particles are only $1/\Lambda_\pi$ -suppressed:

$$L_{TeV} = \left[\frac{1}{\bar{M}_{Pl}} h_{\mu\nu}^{(0)}(x) + \frac{1}{\Lambda_\pi} \sum_{n=1}^{\infty} h_{\mu\nu}^{(n)}(x) \right] T^{\mu\nu}(x), \quad (6)$$

and their signature may appear at LHC. In (6), $T^{\mu\nu}$ is the energy-momentum tensor and $h_{\mu\nu}^{(0)}$ denotes the zero-mode, ordinary, graviton.

The RS model parameters are the mass of the lowest graviton excitation, $M_G = M_j$, and the dimensionless coupling $c = k/\bar{M}_{Pl}$. Theoretically, ‘‘natural’’ ranges of these parameters are $0.01 \leq c \leq 0.1$ and $\Lambda_\pi < 10$ TeV. With $\Gamma_n = \rho M_n x_n^2 c^2$ and ρ a number of order unity, narrow graviton resonances are expected for such small values of c . LHC 95 % CL limits on M_G is of order 4.1 TeV ($c = 0.1$). Thus, due to the high allowed values of M_G , the discovery could be limited to the lightest M_j and the verification of the predicted mass pattern hardly feasible, so that the spin-2 determination through the angular analysis becomes a crucial test of the model.

For dilepton production, the leading order subprocesses $\bar{q}q \rightarrow G \rightarrow l^+l^-$ and $gg \rightarrow G \rightarrow l^+l^-$ give for the z -even distributions needed in A_{CE}^G , with self-explaining notations:

$$\frac{d\sigma^G}{dz} = \frac{3}{8}(1+z^2)\sigma_q^{SM} + \frac{5}{8}(1-3z^2+4z^4)\sigma_q^G + \frac{5}{8}(1-z^4)\sigma_g^G, \quad (7)$$

and

$$A_{CE}^G = \varepsilon_q^{SM} A_{CE}^{SM} + \varepsilon_q^G \left[2z^{*5} + \frac{5}{2}z^*(1-z^{*2}) - 1 \right] + \varepsilon_g^G \left[\frac{1}{2}z^*(5-z^{*4}) - 1 \right]. \quad (8)$$

In (8), ε_q^G , ε_g^G and ε_q^{SM} are the fractions of G -events under the peak at M_R initiated by $\bar{q}q$ and gg processes, and the SM background, respectively. They are determined by overlaps of parton distribution functions and, obviously, $\varepsilon_q^G + \varepsilon_g^G + \varepsilon_q^{SM} = 1$. Strictly, Eqs. (7) and (8) are quite transparent in showing the characteristic z (and z^*) dependencies for the spin-2 graviton, but hold in that form only for $z_{cut} = 1$. Moreover, next-to-leading order terms in QCD have for simplicity been included in the calculations through flat (in z) K -factors, $K \approx 1.3$.

For diphoton production (1), retaining only the leading order RS resonance exchange contributions to simplify the presentation, $\bar{q}q \rightarrow G \rightarrow \gamma\gamma$ and $gg \rightarrow G \rightarrow \gamma\gamma$, the analogues of Eqs. (7) and (8) with the same significance of the notations can be written as:

$$\frac{d\sigma^G}{dz} = \frac{5}{8}(1-z^4)\sigma_q^G + \frac{5}{32}(1+6z^2+z^4)\sigma_g^G, \quad (9)$$

and

$$A_{CE}^G = \varepsilon_q^G \left[\frac{1}{2} z^* (5 - z^{*4}) - 1 \right] + \varepsilon_g^G \left[-1 + \frac{5}{8} z^* + \frac{5}{4} z^{*3} + \frac{1}{8} z^{*5} \right]. \quad (10)$$

It turns out that in this case the gg -initiated subprocess is the dominant, with a shape peaked at $z = 1$ similar to the SM background but by far overwhelming it for the order TeV values of M_G we here are interested in. Clearly, the interest of the diphoton channel is that vector state does not decay into $\gamma\gamma$ and it leaves only the spin-2 and spin-0 hypotheses, and that the ratio $Br(G \rightarrow \gamma\gamma) / Br(G \rightarrow l^+l^-) \approx 2$ is predicted.

1.2. New neutral gauge bosons. Turning to the spin-1 hypothesis, Z' models depend, besides the mass $M = M_{Z'}$, on left- and right-handed couplings to quarks and leptons. In popular scenarios we refer to, generated by different extended electroweak gauge symmetries, those couplings are fixed theoretically, so that only $M_{Z'}$ would remain as a free parameter. This is the case of the Z'_χ , Z'_η , Z'_ψ , Z'_{LR} , Z'_{ALR} models, and the “sequential” Z'_{SSM} model with the same couplings as the SM (details can be found in [1]). Current LHC lower limits (95 % CL) on these Z' masses lay within the range from 4.0 TeV to 4.5 TeV, depending on the model.

Actually, the leading-order partonic subprocess $\bar{q}q \rightarrow Z' \rightarrow l^+l^-$ leads to the same form of the z -even angular distribution as the SM, therefore to the same A_{CE} for all models:

$$\frac{d\sigma^{Z'}}{dz} = \frac{3}{8} (1 + z^2) (\sigma_q^{\text{SM}} + \sigma_q^{Z'}), \quad (11)$$

and

$$A_{CE}^{Z'} \equiv A_{CE}^{\text{SM}} = \frac{1}{2} z^* (z^{*2} + 3) - 1. \quad (12)$$

Our A_{CE} -based estimates for exclusion of the spin-1 Z' hypothesis will, accordingly, have a considerable degree of Z' model-independence.

1.3. Sneutrino in R -parity-violating SUSY. The spin-0 character of the resonant subprocess $\bar{d}d \rightarrow \tilde{\nu} \rightarrow l^+l^-$, leading to a peak at $M = M_{\tilde{\nu}}$, manifests itself in a flat angular distribution:

$$\frac{d\sigma^{\tilde{\nu}}}{dz} = \frac{3}{8} (1 + z^2) \sigma_q^{\text{SM}} + \frac{1}{2} \sigma_q^{\tilde{\nu}}, \quad (13)$$

$$A_{CE}^{\tilde{\nu}} = \varepsilon_q^{\text{SM}} A_{CE}^{\text{SM}} + \varepsilon_q^{\tilde{\nu}} [2z^* - 1]. \quad (14)$$

Besides $M_{\tilde{\nu}}$, the cross section is proportional to the R -parity violating product $X = (\lambda')^2 Br_l$ where Br_l is the sneutrino leptonic branching ratio and λ' the relevant sneutrino coupling to the $\bar{d}d$ quarks. Current constraints on X are very loose (we may take the range $10^{-5} < X < 10^{-1}$).

2. Spin-2 identification

There are wide domains in M_R and coupling constant values allowed by current experimental limits where the scenarios described above predict the same peaks in M with the same numbers of events, so that they cannot be distinguished from each other on the basis of the event rates only.

To proceed with the spin-identifying angular analysis, we suppose that a peak at $M = M_R$ is discovered in process (1), and assume that it is consistent with a spin-2 RS graviton (in which case $M_R \equiv M_G$). To evaluate the domain in the (M_G, c) plane, where the competitor spin-1 and spin-0 hypotheses with the same number of events under the $M = M_G$ peak as the graviton hypothesis can be excluded, hence the spin-2 hypothesis can be established, we look at the “distances” among models:

$$\Delta A_{CE}^{Z'} = A_{CE}^G - A_{CE}^{Z'}, \quad \Delta A_{CE}^{\tilde{\nu}} = A_{CE}^G - A_{CE}^{\tilde{\nu}}. \quad (15)$$

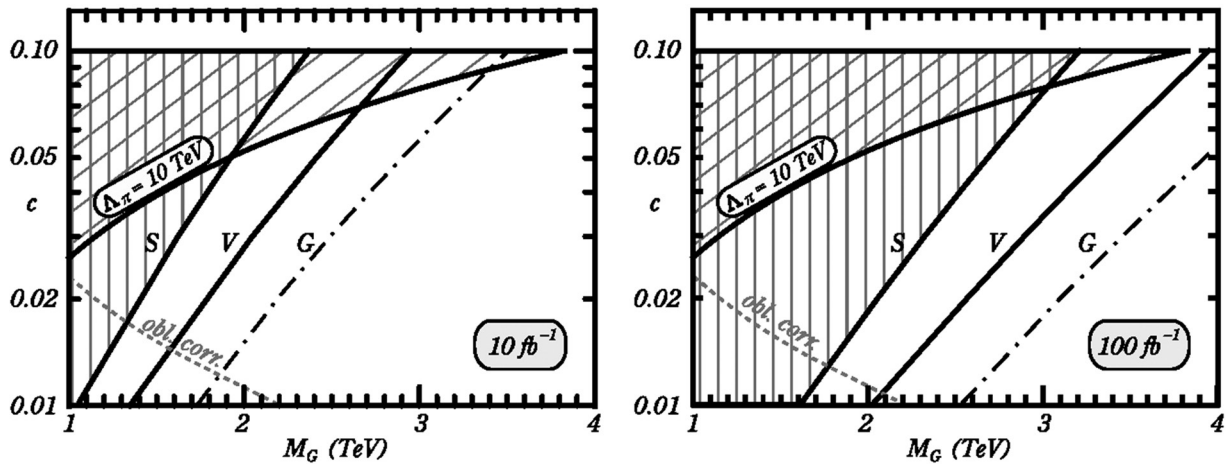
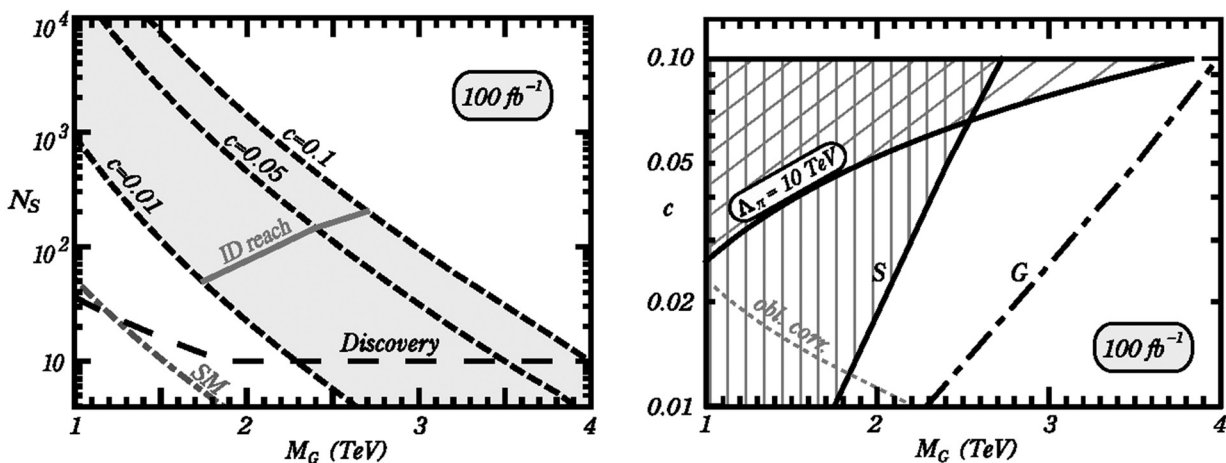

Fig. 1. Discovery and identification ranges obtained in dilepton final states as defined in the text

We adopt a simple-minded χ^2 -like criterion, where the deviations (15) are compared to the expected statistical uncertainty $\delta A_{CE}^{Z'}$ pertinent to the RS model (systematic uncertainties can also be included). The χ^2 for the Z' and the sneutrino cases in (15) is defined as $\chi^2 = |\Delta A_{CE}^{\tilde{\nu}} / \delta A_{CE}^{Z'}|^2$.

Fig. 1 shows the 5- σ discovery domains and the 95 % identification domains for LHC luminosity of 100 fb^{-1} ($l = e, \mu$ combined), and the “theoretically favoured” restriction $\Lambda_\pi < 10 \text{ TeV}$ taken into account. Specifically: the area at the left of the line “G” is the discovery domain for the lowest-lying RS graviton resonance; the area at the left of the “V” curve is the exclusion domain of the spin-1 hypothesis; finally, in the area at the left of the “S” line the spin-0 (and, as one can see, forcefully the spin-1) hypothesis can be excluded. Therefore, the identification domain where both spin-1 and spin-0 hypotheses can be excluded and the spin-2 established is the intersection of the “S” area with the $\Lambda_\pi < 10 \text{ TeV}$ one, i.e., above that curve. The allowed domain to the right of the dashed “oblique corrections” line is qualitatively determined by a fit to the oblique EW parameters, but the condition dramatically restricting the discovery domains to the dashed areas, if literally applied, is the Λ_π bound. This condition essentially forbids the creation of additional mass scale hierarchies in the model.

Fig. 2 shows some attempts to assess both discovery and identification reaches on the spin-2 RS graviton from the diphoton production channel in (1). Specifically, the left panel shows, for $0.01 \leq c \leq 0.1$ the minimum number of events needed to identify by means of the center-edge asymmetry a peak at diphoton invariant mass M_G as an RS resonance, against the spin-0 hypothesis (95 % CL and LHC luminosity of 100 fb^{-1}). Leading order QCD (therefore unit K-factors) has been used to obtain this figure.

 Fig. 2. Discovery and identification from the process $pp \rightarrow \gamma\gamma + X$

The right panel of Fig. 2 represents, with the same style as Fig. 1, the translation to the (M_G, c) RS parameter plane of the minimum number of diphoton events for RS graviton identification given in the left panel.

Acknowledgments. This research has been partially supported by the Abdus Salam ICTP (TRIL Programme) and the Belarusian Republican Foundation for Fundamental Research.

References

1. Pankov A. A., Serenkova I. A., Tsytrinov A. V., Bednyakov V. A. Prospects for identification the direct and indirect effects of extra spatial dimensions at the large Hadron Collider. *Physics of Particles and Nuclei*, 2017, vol. 48, no. 1, pp. 415–454. Doi: 10.1134/s1063779617030066

Information about the authors

Alexander A. Pankov – D. Sc. (Physics and Mathematics), Professor, Chief Scientist, Sukhoi State Technical University of Gomel (48, October Ave., 246746, Gomel, Republic of Belarus). E-mail: pankov@ictp.it

Inna A. Serenkova – Ph. D. (Physics and Mathematics), Leading Researcher, Sukhoi State Technical University of Gomel (48, October Ave., 246746, Gomel, Republic of Belarus). E-mail: Inna.Serenkova@cern.ch

Andrei V. Tsytrinov – Ph. D. (Physics and Mathematics), Associate Professor, Sukhoi State Technical University of Gomel (48, October Ave., 246746, Gomel, Republic of Belarus). E-mail: tsytrin@rambler.ru

Vadim A. Bednyakov – D. Sc. (Physics and Mathematics), Professor, Director of the Laboratory of Nuclear Problems of JINR (6, Joliot-Curie Str., 141980, Dubna, Moscow Region, Russian Federation). E-mail: bedny@jinr.ru

Информация об авторах

Панков Александр Альбертович – доктор физико-математических наук, профессор, главный научный сотрудник Гомельского государственного технического университета им. П. О. Сухого (пр. Октября, 48, 246746, г. Гомель, Республика Беларусь). E-mail: pankov@ictp.it

Серенкова Инна Александровна – кандидат физико-математических наук, ведущий научный сотрудник Гомельского государственного технического университета им. П. О. Сухого (пр. Октября, 48, 246746, г. Гомель, Республика Беларусь). E-mail: Inna.Serenkova@cern.ch

Цитринов Андрей Викторович – кандидат физико-математических наук, доцент, доцент кафедры информационных технологий Гомельского государственного технического университета им. П. О. Сухого (пр. Октября, 48, 246746, г. Гомель, Республика Беларусь). E-mail: tsytrin@rambler.ru

Бедняков Вадим Александрович – доктор физико-математических наук, профессор, директор лаборатории ядерных проблем ОИЯИ (ул. Жолио-Кюри, 6, 141980, г. Дубна, Московская обл., Российская Федерация). E-mail: bedny@jinr.ru